

Energy and Water Solutions

A Division of Awesome Pool Products, LLC

902 West 2010 South, Syracuse, Utah 84075

Voice: 801-825-5580 Fax: 801-825-5428

Website: www.ewsews.com Email: sales@ewsews.com

EWS

Model CNGCARB

CNG Conversion Kit Instructions and Owner's Manual For all Carbureted Engines

CNG Conversion Kit Parts List – Check to make sure your kit is complete before beginning.

Closed Loop Feed Back Controller, Stepper Motor with Wire Harness and Parts Bag
Carburetor Change-Over Switch and Fuel Indicator with Pressure Gauge, Wire Harness and Parts Bag
Mixer
Foam Rubber Spacer for Mixer (if needed)
Regulator
Regulator Bracket
Filling Nozzle with Valve
Filling Nozzle Bracket
Roll of 6mm HP Tubing
6 ft of 5/16" Heater Hose
3 ft of 3/4" Fuel Hose
Instructions and Owner's Manual
CNG Sticker

1 Bag of the Parts Below:
3 High Pressure 6 mm Compression Fittings
5 High Pressure 6 mm Ferrules
5 High Pressure Tubing Straps
Aluminum Fitting for Mixer
4 Small Heater Hose Clamps
6 Large Heater Hose Clamps
4 Large Fuel Hose Clamps
3" of 3/8" Heater Hose
2 Reducing Heater Hose Tees
1 Spade Connector
1 3/8" Hole Connector
6 Large Wire Ties
6 Small Wire Ties
8 Heat Shrink Tubing Caps
9 Self Tapping Screws

Disclaimer

1. No Refunds on Used or Opened CNG (Compressed Natural Gas) Conversion Kits, CNG Parts, or CNG Cylinders.
2. Refunds are only with Return Authorization and have a 20% restocking fee.
3. Shipping Is Non-Refundable on all our products sold.
4. Our CNG Conversion Kits are not EPA or DOT certified.
5. Some of our CNG Cylinders are not DOT Certified, but are ISO Certified.
6. All CNG Conversion Kits, CNG Parts, or CNG Cylinders Installed or not Installed are considered Do It Yourself and are installed at your own risk.
7. Installation of CNG Conversion Kits, CNG Parts, or CNG Cylinders is Buyers Responsibility to Obtain, Perform, and Maintain.
8. By purchasing any of our products you agree To Forever Hold Harmless, Indemnify, and Covenant Not to Sue Energy and Water Solutions or anyone affiliated with Energy and Water Solutions.

9. The One-Year Warranty Provided by Energy and Water Solutions is only for Workmanship and Quality of the CNG Conversion Kits, CNG Parts, or CNG Cylinders.
10. We do not guarantee that you will not get a “Check Engine” light after installing our CNG Conversion Kits.
11. You agree to these terms and conditions by Viewing, Sharing, or Purchasing our information and products.
12. Individual Results May Vary In All Aspects and Respects Not Limited.
13. We reserve the right to change these terms at anytime for any reason without notice.

Install the conversion kit while the engine is cool.

Completely read these before proceeding. If you do not have a service manual you should buy one at your local auto parts store or an online service. It will help you find many wires and parts much easier.

Regulator Installation

1. Find a location to install the regulator as close as possible to the air intake hose were the mixer will be installed. The regulator should be installed with the gas outlet at the bottom. Mount using the 8” bracket provided using 2 self tapping screws installed to the fire wall or side wall. You may need to place the bracket in a vice to bend it to fit.
2. At the front of the regulator below the water hose connections is the screw to adjust the low RPM regulation or idle.
3. On the side of the regulator you will find another screw. Do not adjust this screw as it regulates the internal pressure and is set at the factory.

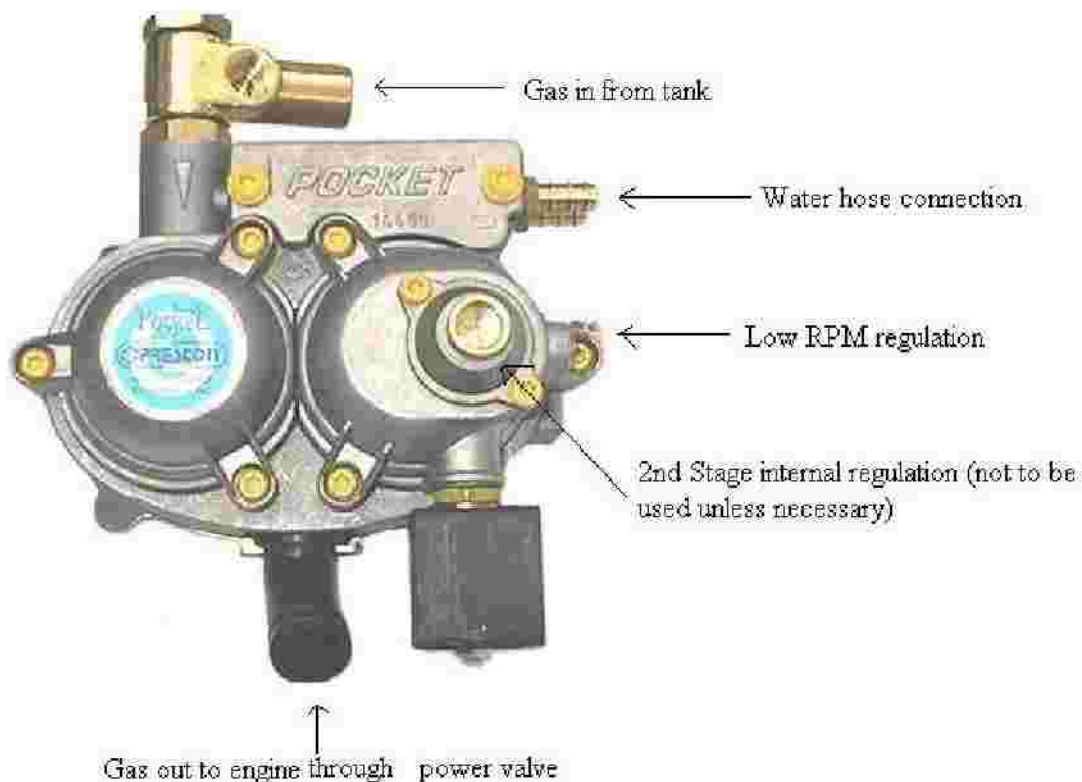

Mixer Installation

1. If you do not have a K&N or similar carburetor adaptor kit we suggest you get one before installing the mixer. It is difficult to install the mixer above the carburetor. It must be installed so all airflow is through the center of the mixer, so that it is held in place securely and so the filter cover can still be installed which can be very difficult on most engines. The following steps explain installation in an intake hose.
2. Completely remove the intake hose from the engine or filter kit.
3. Check the mixer for proper fit into the intake hose. The mixer should be installed between the air filter and the throttle body where it is easiest to install and where the hose is easiest to connect to from the regulator. If your engine has a turbo charger the mixer must be installed between the air filter and the turbo charger and not after the turbo charger. The end of the mixer that has the ring snapped into it with a slope and angled ribs to the center is the upstream side of the mixer where the air will flow into the mixer. It will not work if installed backwards. A 60% to 70% reduction of the air intake through the mixer is normal. All air

must flow through the center of the mixer and no air should flow around the mixer. Remove the aluminum fitting from the mixer. Place the mixer in the hose. If it is a loose fit, wrap enough of the foam rubber if supplied around the mixer to create as tight of a fit as possible so no air will leak around the mixer and so the mixer is held in place firmly so it will not move. You must use a method of holding the mixer in place so that it cannot move by using a clamp around the hose if it is flexible, a silicone or similar sealant, or screws. You will need to cut a hole in the foam where the fitting will thread into the mixer and align the hole for the fitting with the hole in the hose.

4. Thread the hose fitting through the hole in the intake hose and into the mixer. Do not over tighten. Make sure the mixer is installed so the intake hose will still fit onto the throttle body and so the hose fitting on the mixer will be in the best location to install the gas hose to it. Make sure you clean any shavings from the hose so nothing will get into the engine.
5. Seal any leaks around the aluminum hose fitting so no air can leak into the intake hose.

Low Pressure Gas Hose and Stepper Motor Installation

1. Locate the stepper motor as close to the mixer as possible. Install the 3/4" ID hose using hose clamps onto the regulator gas out fitting, stepper motor, and mixer. Cut the hose as needed. Use the clamps that are opened with pliers. Place the clamps about 3" onto the hose before inserting the fittings onto the hose.
2. Open the clamp with pliers and slide over the fitting.

Heater Hose Connection

1. Locate the 2 heater hoses going to the heater core. Make sure they are not air conditioning lines. Do not install with the engine hot. Cut each hose at the most convenient location to install a reducing tee into each hose. Make sure the heater shut off control is not between the engine and the tee connection. The 5/8" reducing tee can be installed on most 1/2", 5/8", or 3/4" heater hose. If only one heater hose is accessible you can connect both tees to one hose with at least 5 inches of hose between the tees. Install a hose clamp between the 2 tees and close off the hose slightly to restrict the flow so some coolant will flow through the regulator, but most will flow through the larger hose.
2. Slide a hose clamp onto each end of the heater hose before inserting the reducing tee onto the hose. Use the hose clamps that are tightened with a screwdriver or socket.
3. Check the 5/16" heater hose to see if it is long enough to connect from the tees to the fittings on the regulator. It should be long enough for most installations. If it is not long enough, purchase enough hose for the shortest connection.
4. Slide a hose clamp onto both ends of the 5/16" hoses.
5. Install the 5/16" hoses to the small center fittings of the reducing tees.
6. Install the two heater hoses to the two heater fittings on the regulator. It makes no difference which hose connects to each fitting.
7. Tighten all the hose clamps tight, but do not over tighten.
8. Wait to check for leaks until after installing your kit and after you start your engine.

How to Safely Install HP (High Pressure) Tubing and Fittings

1. Use only extreme pressure fittings and tubing rated for at least 3,000 psi. All tubing and fittings included in your conversion kit are extreme pressure fittings rated at 3,000 psi or higher.
2. Make all bends by hand slowly and carefully bending only slightly along its length.
3. If needed use a 1/4" tubing bender if you need to bend any small radius bends.
4. Do not use any tubing that has been kinked or damaged from improper bending or damaged while installing.
5. Use a helper to run the long length of tubing from the cylinder to the engine area to avoid damaging the tubing by kinking it or scrapping it.
6. If the end of the tubing is not sealed, tape the end while installing so nothing gets into the tubing.
7. Slide the nut and then the ferrule onto the tubing before threading the nut onto the fitting. Make sure at least 2 inches of the end of the tubing is straight so the fittings will slide onto the tubing. Be careful not to drop and lose the nuts or ferrules. Two extra ferrules are included in the kit in case they are dropped or need to be redone. Do not replace any parts with lower pressure parts available at your local hardware or plumbing store.
8. Insert the tubing all the way into the fitting and make sure it does not slide out while tightening the nut.
9. Always use two wrenches so one wrench is opposing the force of the wrench on the nut when tightening any fittings, and tighten tight, but do not over tighten.
10. Do not twist or bend the tubing while installing fittings.
11. Never use any thread sealant on compression fittings.
12. After tightening any fittings make sure the tubing does not move when pulling, twisting, or wiggling back and forth. Make sure the nut is tight. If the tubing can be moved at all you did something wrong. Remove the nut and make sure the ferrule is firmly attached to the tubing and not on the very end of the tubing. If not, you will need to use a new high-pressure ferrule of the same type and start again.

13. Use 6 to 8 wraps of Teflon tape to all male pipe threaded fittings and wrap in the same direction as when tightening.
14. Leave a little slack in all tubing runs to allow for expansion and contraction.
15. Only cut the HP tubing with a tubing cutter. Cut slowly only cutting a little with each rotation of the tubing cutter. The tubing is hard steel and cutting fast will damage the tubing cutter and the tubing. Ream out the tubing after it is cut making sure to not get anything in the tubing. If you do not ream out the tubing it will take longer to fill with CNG. Make sure no shavings are left in the tubing that could damage the regulator or your engine.

Installing the HP (High Pressure) Tubing and Fittings

1. Read the instructions above before proceeding.
2. Install the CNG cylinder to the vehicle following the cylinder installation instructions.
3. If the cylinder is installed in the vehicle or in the truck, and the cylinder valve has a blow off, it must be vented to the outside using at least an 8 mil thick bag or hose. With our valves connect a 3/4 ID hose and a hose clamp connected to the cylinder valve and over the blow off nut with the three holes and vent to the outside. Make sure the clamp is not installed over the vent holes so the air path is blocked. Drill a hole to the outside and rout the bag or hose to the outside under the vehicle and seal the hole around the hose or bag with silicone sealant.
4. Drill 1/2" holes where needed to rout the tubing from the cylinder area to the engine area.
5. Use the 3" length of 3/8" heater hose to slide over the tubing and half way into the hole to protect the tubing.
6. Mount the filling nozzle under the hood, near the regulator, and where it is convenient to fuel the vehicle using the 6" bracket provided. It may be possible to mount the nozzle near the front grill where it can be accessed without raising the hood if the grill has large spacing.
7. The nozzle end must be located so the filling station nozzle can easily be connected to it. The filling station nozzle is about 16" long so make sure there is room to connect it to your nozzle.
8. Go to your nearest CNG filling station and check out the nozzle and how it operates, and how the gas is purchased. Try to closely watch at least one vehicle fuel while you are there. Do this step before you begin the installation of your conversion kit.
9. Install HP tubing from the cylinder valve to the port with the mounting nut on the filling nozzle. Do not locate the tubing near any moving parts, or hot exhaust or engine parts. When running the tubing under the vehicle, keep the tubing above other car parts when possible to keep it up as high as possible where it is better protected from damage. The tubing must not be installed so that it is below the frame of the vehicle where it is in a crush zone where it can be crushed.
10. Strap the HP tubing in place every 18" to 24" using the self-tapping screws provided and the thin flat metal straps provided. Just simply bend them to make a strap.
11. Install the pressure gauge include with your kit to the shorter port of the gas in tee fitting of the regulator. Do not tighten the pressure gauge by turning the gauge. Tighten only by using a wrench on the square head fitting. Use the thick aluminum washer supplied to the back of the pressure gauge to make the seal. Place it on the end before threading it onto the regulator.
12. Install a length of HP tubing from the other fitting of the filling nozzle to the tee fitting on the top of the regulator.
13. Tighten the nut on the top of the regulator when you have it turned to the desired position. It has o-rings so do not over tighten it.
14. Tighten the silver filling nozzle with a wrench after it is installed. It has an o-ring so do not over tighten it.

Electronics

Wiring Tips

1. Locate all sensor wires you can with the ignition on and without starting the engine.
2. Do not turn the ignition on until you are ready to locate each sensor wire or ignition wire, and only for a minute or two.
3. You can make the connections at the sensor connector, or if you have a wiring diagram and can locate the wires, at the main wire harness just before it enters the fire wall.
4. Locate a good chassis ground and place the black test lead under a bolt and tighten slightly so that you do not have to hold it while testing for voltages. Set the meter to read resistance and place the red test lead to the battery negative and check for near zero resistance to verify a good ground.
5. Leave the sensor connector plugged in while locating the sensor wires.
6. Gently insert the red test lead from where the wire enters the connector, between the sensor wire and the rubber seal about 3/8" to reach the connector pin, and read the voltage.
7. Make sure you have the test meter set to the proper DC voltage range for the wire you are locating. You will be reading voltages from a few milli-volts to battery voltage. To read milli-volts, set the meter to the lowest DC voltage range. If you are using an auto-range meter make sure you note the voltage range when reading the voltage.

8. After locating the proper wire you will connect to, expose 6" inches of wire and cut the wire, or strip ¼" length the insulation off the wire, 3" from the connector. If you cut the wire make sure you reconnect both ends of the wire to the new wire and solder. If you just strip off the insulation, wrap the new wire around the existing wire and solder. The fuel injector wires must be cut when wiring and not reconnected to each other. You will need to remove the plastic wire protector from the wires to expose the wire.
9. Solder all wires to the spade connectors that will be connected to the fuse holders and to the solenoid. Insert the insulators on the wire before soldering so they can be inserted over the spade connector.
10. All ground wires will be connected together from every controller and connected to a good chassis ground. All wire connections should be soldered and covered with heat shrink tubing caps or electrical tape. Use a heat gun or hair dryer on high to shrink the tubing. The hair dryer is slower, but it will work. Be careful not to overheat the tubing or wires, or anything behind the wires.
11. If you do not have a pensile type soldering iron, flux and solder you will need to purchase them. Make sure all wires and connectors are fluxed before soldering. All wires that are not used must be insulated. Do not connect any wires that are not shown connected in the wiring diagrams!
12. Do not install the fuses in the fuse holders until all wiring is completed, the cylinder is filled with CNG, and you are ready to start the engine.

Read the above wiring tips and use them for all the following steps. Below is wiring information for each wire connection. Also see and study the wiring diagrams on the following pages.

Carburetor Change-Over Switch Installation

1. Plug the wire harness into the back of the controller.
2. Make sure the pin connector on the back of the controller is in the carburetor mode. See wiring diagram.
3. Mount the controller on, in, or under the dash near the driver where it is in view of the driver. If you have a small compartment it will fit into and can be mounted in, this is the best location. Use the bracket and screws provided. The hole in the bracket near the edge is the front of the bracket.
4. Screw the bracket in place with the smooth side up.
5. Slide the controller onto the bracket.
6. Run the wire harness through the fire wall from inside the vehicle.
7. Tie the wire harness up out of the way inside the vehicle with wire ties.
8. Wire according to the wire diagram and instructions below.

Gasoline Solenoid Installation

1. Mount the solenoid valve near the fuel line and near the carburetor.
2. Cut the fuel line near the solenoid valve and install the fuel lines to it using 2 of the large hose clamps.
3. Wire according to the wire diagram above.

Connecting the Wires to the Fuel Line Solenoid Valve

1. Connect a black chassis ground wire to the mounting bracket of the fuel line solenoid and make sure it has a good electrical connection. Use the extra length from one of the black wires from one of the controllers if possible.
2. Connect the green wire from the Carburetor Controller to the positive terminal of the solenoid valve using a spade connector. Crimp and then solder the wire to the connector.
1. Tighten the nut that holds the solenoid, but do not over tighten it. If the nut ever gets loose the solenoid will not get power and the solenoid will not energize and gasoline will not be turned off when operating on CNG.

Connecting the brown wire to the High Tension Wires

1. Wrap the brown wire to 2 to 4 spark plug wires by wrapping it 3 to 4 times around the wires.
2. Tape or wire tie in place. Do not connect to the spark plug wire inside the insulation.

Locating and Connecting the 12-volt Battery Wire

1. Connect the red wire from the FBS Controller to the fuse holder and then from the fuse holder to the 12-volt battery wire. This can be at the battery or any other wire that always has 12-volt battery. You will need to cut a 6" length of the red wire first. Make sure the fuse is not installed at this time.

Locating and Connecting the 12-volt Ignition Wire

1. Locate a 12-volt ignition wire under the dash. Use your service manual to help locate a wire. Make sure the wire turns off and on with the ignition. Do not use a wire that turns on with just accessories on.

2. Connect the red wire from the Carburetor Chang-Over Switch to the 12-volt ignition wire.

Locating and Connecting the Chassis Ground

1. Connect all ground wires from all controllers, pressure gauge, and gasoline solenoid to a good chassis ground and to the mounting bolt on the regulator.

Connecting the Wires to the Regulator Solenoid Valve

2. Connect a ground wire to the mounting bolt on the back of the regulator using the 3/8" hole connector. Use the extra length from one of the ground wires from one of the controllers. Crimp and then solder the wire to the connector.
3. Connect the blue wires from the FBS controller and Carburetor controller to the positive terminal of the solenoid coil using a spade connector. Crimp and then solder the wires to the connector. If any of the blue wires are not connected the system will not operate properly.
4. Tighten the nut that holds the solenoid coil on, but do not over tighten it. If the nut ever gets loose the solenoid will not get power and the solenoid will not energize and the regulator will not operate.

Installing and Connecting the Oxygen Sensor Wire

1. Have the oxygen sensor bung provided welded to the exhaust system near the engine where it is convenient.
2. Thread the oxygen sensor into the bung.
3. Cut the plug off of the sensor wire and wire to the white wire of the FBS Controller.

Connecting to the Pressure Gauge Level Sensor

1. Connect the connector and wires supplied to the pressure gauge.
2. Connect the black wire from the gauge to ground. Cut the ring connector off if not needed.
3. Connect the white wire from the gauge to the white wire from the carburetor controller.
4. Connect the yellow wire from the gauge to the yellow wire from the carburetor controller

Final Wiring

1. Plug all wire connectors into the proper controllers, emulators, stepper motor, and fuel level sensor (pressure gauge).
2. Install the controllers, and emulators to the back fire wall or wherever the best location is to mount them to your vehicle. They should be installed upright with the connector at the bottom with the rubber boot over the connectors to keep the connections clean and dry.
3. Insulate all wires not used. Do not connect any spare wires that are not shown connected in the wire diagrams!
4. Use the wire ties provided to organize and support all the wires.
5. Make sure all wires are away from any moving parts, hot exhaust or engine parts, or high-tension spark plug wires.
6. Install the CNG sticker to the back of the car on the right side.

Carburetor Change-Over Switch Wiring Diagram

Read and follow the Instructions before wiring.

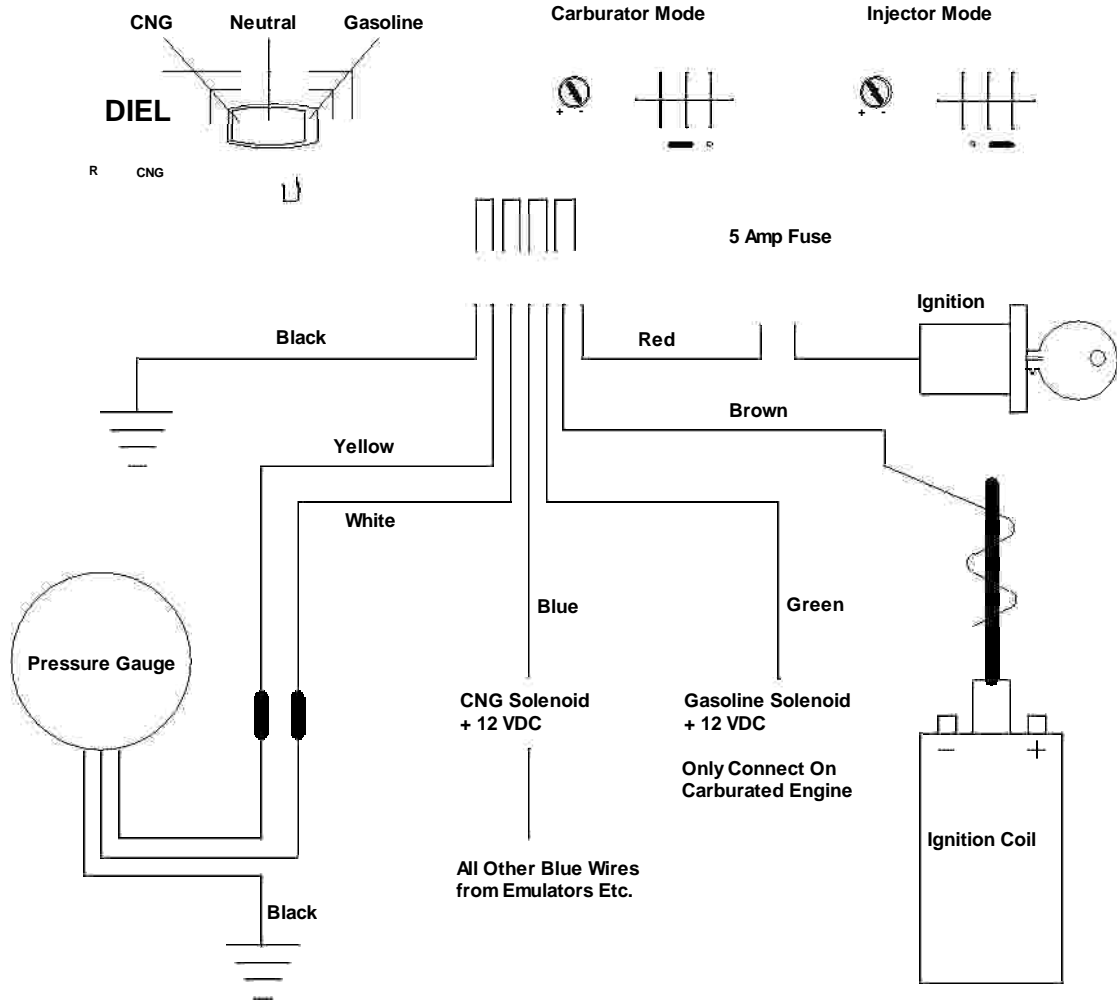

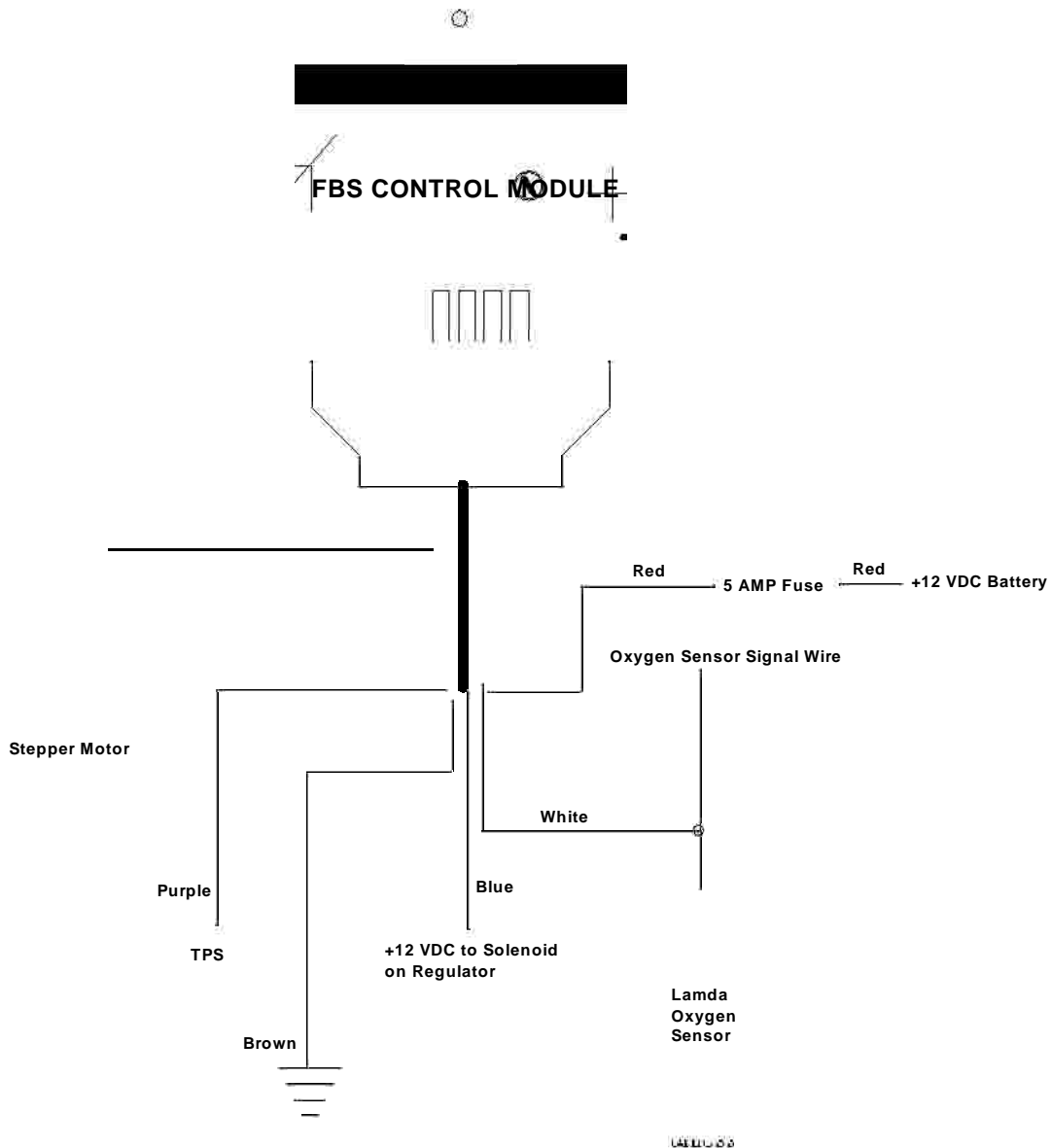

Cylinder (Storage Tank) Location

1. Locate the cylinder in the truck of a car, the front of a truck bed, or behind the rear seat of a SUV or van. The cylinder can be installed under the vehicle on some vehicles. More than one cylinder can be installed to provide a longer driving range.
2. Check to see that the cylinder can be strapped down securely at the desired location.
3. Make sure you have room to install the cylinder valve and to open and close the cylinder valve.
4. Make sure you have room to install the high-pressure tubing to the cylinder valve.
5. If the cylinder is installed in the vehicle or in the truck, the blow off on the cylinder valve must be vented to the outside using at least an 8 mil thick bag or hose. Our valves will vent with a $\frac{3}{4}$ ID hose and a hose clamp connected to the cylinder valve and over the blow off nut with the three holes. Make sure the clamp is not installed over the vent hole so the air path is blocked. Drill a hole to the outside and rout the bag or hose to the outside under the vehicle and seal the hole around the hose or bag with silicone sealant.

Strapping the Cylinder in Place

1. You will need to purchase our mounting brackets or have mounting brackets fabricated capable of supporting at least 10 times the weight of the cylinder. Each cylinder must have at least 2 straps that completely surround the cylinder with contact around its entire circumference.

2. The straps must be bolted in place with 1/2" steel bolts with oversized 2" or larger washers and 1/2" lock washers. Do not mount with screws or lag bolts.
3. You must purchase and install 1/8" rubber anywhere the cylinder comes in contact with the vehicle and between the cylinder and the straps to eliminate vibration damage to the cylinder.
4. The cylinder must be held in place to eliminate any movement up or down, side-to-side, or front to back as the vehicle is in motion and to hold it securely in place in case of an accident.
5. Make sure you check under the vehicle or on the other side of any surface before drilling any holes to make sure you can attach the washers and nut to the bolt when inserted in the hole, and that you do not drill into any wires, fuel tank, or other obstructions.
6. Drill the hole for the high-pressure tubing to exit the trunk, truck bed, or vehicle at the same time if needed.
7. The straps must be tight, but do not over tighten the straps to put excessive pressure on the cylinder.

Installing the Cylinder Valve

1. Apply gas pipe dope to the cylinder valve threads.
2. Thread the valve into the cylinder as tight as possible. Remove the valve handle. Use a large pipe wrench around the body of the valve and not around the end fittings. A wrench on the end of the valve may damage the valve by flattening the treads out of round. Tighten as tight as possible without damaging the valve.
3. Reinstall the handle.

How to Fill the CNG Cylinder

1. After completing all the steps above, you are ready to fill your CNG cylinder. Do not fill it before then.
2. Double check that all high-pressure connections are tight, the cylinder is secure, and the tubing is secure and will not be damaged while operating the vehicle.
3. Leave all fuses until you return home and are ready to run the engine on CNG.
4. Drive to your local CNG filling station.
5. Bring the wrenches needed to tighten any fittings if there is a leak.
6. Bring your soap test leak towel. All you need is several drops of dish soap on a couple of very wet paper towels. Rub the towels vigorously on all fittings to create suds and watch for any air bubbles, which indicate a leak.
7. Do not fill the cylinder with anyone in or near the vehicle during the first filling, and until the cylinder and the entire CNG system is filled to capacity and you are sure there are no leaks by testing for leaks.
8. Open the cylinder and filling nozzle valves before filling.
9. Read and follow the filling station instructions.
10. Connect the filling station nozzle to your filling nozzle.
11. Before filling be ready to check for leaks as soon as the gas is turned on. Turn the CNG gas off and the cylinder valve off if you hear or see any leaks. Repair all leaks and then turn on your cylinder and filling nozzle valve. Check for leaks again.
12. If there are no leaks continue to fill the cylinder to 200 bar or 3,000 psi. If the filling station pressure is low you may not be able to reach the desired pressure. Do not overfill your cylinder.
13. Disconnect the filling nozzle.
14. Check for leaks again with the soap test
15. It is normal for the cylinder to get warm when filling, and for the pressure of the cylinder to drop slightly after it cools.
16. Always when opening the cylinder valve just open it slightly and slowly until the pressure equalizes. Then open it all the way.
17. Drive home to make adjustments before driving on CNG.

Start up and Adjustment

1. Make sure you have completely read and understand all of these instructions before proceeding.
2. Check the cylinder pressure gauge again. If the pressure is still reading about the same pressure, proceed to step 2. If the pressure has dropped, check for leaks again.
3. Turn on the cylinder valve and filling nozzle valves.
4. Raise the hood and leave it open.
5. Install the fuses into the fuse holders.
6. Your FBS controller comes programmed with our program that works on all engines. You do not need to program the controller. All you need to do is adjust the idle screw on the regulator as instructed below, and your engine will run properly if all wiring is installed properly and the mixer is installed properly. Your FBS controller is self adjusting and continuously adjusts itself for optimum performance. Once adjusted properly it will always run at peak performance.
7. Switch the carburetor change-over switch to the center neutral position.
8. Start the engine. It will start on gasoline. Run the engine at various speeds until the engine just begins to lose power as it runs out of gasoline.

9. Push the switch to the left CNG position. The engine should change to CNG. The engine may stall the first time. If the engine stalls, start the engine again leaving the switch in the CNG position. If the engine does not convert to CNG, check all the wiring to find the problem. See the trouble shooting section below. When the engine converts to CNG, the green CNG light will come on and the 4 green fuel level lights will come on if the cylinder is full. The 4 green lights will go out one at a time as the pressure in the cylinder drops. When it is near empty the red light will come on.
10. Let the engine run on CNG for 3 minutes varying the engine speed from idle to 3,000 RPMs.
11. Let the engine idle.
12. Observe the lights of the FBS controller. They can be seen through the cover from the top or end. They should change equally from green to red every 5 to 15 seconds. This is normal and indicates the oxygen sensor is connected and working properly. Green indicates lean fuel and red indicates rich fuel. If the green or orange light only lights the idle screw will need turned out counter clockwise to run richer. If the red light only is on the screw will need turned in clockwise. Turn the idle screw on the regulator ½ rotation at a time and wait at least 30 seconds to see what the lights do before making any other adjustments. If it is running lean or rich adjust until the red and green lights alternate on. The idle screw on the regulator is the hex head brass knob near the heater hose fittings and is turned by hand. Be careful not to unscrew it all the way.
13. Continue to adjust the idle screw in clockwise (lean) ½ turn at a time until the red light does not come on.
14. Turn the idle screw out counter clockwise ½ turn. Wait and make sure the red light comes on. If it does not turn ½ turn counter clockwise again. The red light and green light should start alternating. When they do you are done and the engine should run great. Adjusting the idle near lean keeps the stepper motor near full open while idling so when the gas pedal is pressed the stepper motor is open and the engine will accelerate at peak performance. If the idle is slow or ruff, turning the idle screw ½ to 1 full turn may be needed. Run the engine from idle to 3,500 rpm a few times and see that it runs properly and idles properly.
15. If the engine runs properly, take a test drive in a low traffic area for several blocks making several complete stops making sure it idles properly. If it is running well, take a test drive to highway speeds and see that it is running properly. You may notice a slight decrease in power. This is normal and is to be expected.
16. If the engine does not run or idle properly adjust the idle screw again as described above. The test drive should have given the controller time to self-adjust and adjusting the idle screw again should fix any problems you may experience.

Operation

CNG Carbureted Change-Over Switch Operation Model CNGCCM

General Description

This Change-Over Switch has been designed especially for use in CNG equipment installed in vehicles with a Carburetor or EFI (Electronic Fuel Injection).

The main characteristics are:

- Two types of operation changed by jumper. Mode 1 Carburetor. Mode 2 EFI.
- Engine starts with gasoline fuel and automatically changes to CNG when the engine reaches the set RPM level.
- Emergency Starting in CNG mode.
- Setting RPM change to CNG.
- CNG level gauge with reserve

Electrical Characteristics

Voltage: 12 VDC.

Max switch current: 10 A

Protection fuse: 5A

Max consumption: 60W

Packaging

Control Unit

Pressure Manometer with Sensor

Wire Harness

Insulating Cases and Terminals

Mounting Screws

5 Amp Fuse

Owner's Manual

Carburetor Operation – Jumper in Carburetor Mode

In this mode, the microprocessor provides all the necessary functions to provide CNG for carbureted vehicles. With the three-position switch you have four possible states: CNG - MIX - GASOLINE – NEUTRAL

CNG: In the CNG mode the vehicle will start with CNG, but only if the microprocessor senses pulses from the brown wire connected to the negative of the ignition coil or when wrapped around one or more spark plug wires. The level of CNG in the cylinder will be displayed indicating that you are in the CNG mode. This is the mode you should use in normal operation. In this mode you can start the engine on CNG and never have to use gasoline. You should use gasoline for a few miles at least one a month to keep the fuel system working properly.

MIX: When changing the switch from the initial position of CNG to the Neutral midpoint position, the mode changes to the MIXED FUEL state. This is a temporary state for the fuel to change from CNG to Gasoline. The gasoline solenoid is opened to let gasoline flow to fill the carburetor while the engine continues to operate on CNG. When the presence of both fuels is felt, you must change the switch to the Gasoline position. The lack of fuel during the filling of the carburetor is avoided, avoiding loss of power when changing from one fuel to the other.

GASOLINE: Once the MIX operation is completed and the switch is in the Gasoline position the circuit will keep the gasoline solenoid open to operate on gasoline fuel, meanwhile do not switch to the CNG mode while in the gasoline mode. The switch must be placed in the Neutral mode first as explained below. The CNG level LED indicators will be off and the Gasoline LED will be on while in this mode.

NEUTRAL: When changing the switch from the initial position of Gasoline to the Neutral midpoint position, the mode changes to the NEUTRAL state. Both solenoids will be closed allowing the carburetor to empty. As soon as you feel the engine begin to run out of gasoline, you must change the switch to the CNG position so the engine will begin to operate on CNG. Operating on both fuels at the same time is avoided. Never change the switch directly from the Gasoline position to the CNG position without waiting for the carburetor to empty.

Do not operate the controller in the Injector mode by moving the jumper.

1. If you run out of CNG or gasoline, you can change the fuel while you are driving by pushing the proper switch as described above. You will notice a slight hesitation as the fuel changes. It is wise to not run out of either fuel when fuel is available.
2. Watch the fuel indicator lights and fill the cylinder with gas when needed. Do not run out of CNG. This system does not automatically switch to gasoline if you run out of CNG.
3. Keep at least ¼ tank of gasoline in your vehicle and when filling with gasoline only fill to ½ tank unless you will need more gas for a long driving range.
4. Turn the cylinder valve off if the vehicle is not going to be used for several days. If the cylinder has been turned off, make sure you turn it on carefully before starting your engine.
5. Never run out of either gas, and never start your engine with the cylinder valve off, or you may get warning lights and the engine may not operate properly and your vehicle may be unsafe to drive. Operate only on gasoline with the black switch pushed to the right position until you have filled the cylinder with CNG and all warning lights have been cleared. You may also need to disconnect the negative battery terminal for several minutes to reset your engines ECU.
6. Visually check your system for leaks or damage each time you fill the cylinder with CNG.
7. If you smell or hear a gas leak, do not start the engine and turn the cylinder valve off and have the leak repaired.
8. It is common for many engines to get a “Check Engine” light while running on CNG and it does not mean your system is not installed and running properly. We recommend purchasing a low cost scanner to read the code and clear it. There are some good buys on www.ebay.com. A lean fuel code is the most common and is nothing to be concerned about.

Maintenance

1. Check your system for proper operation and damage each time you fill with CNG.
2. Check for leaks monthly using the soap test.
3. Check hoses and pressure lines for damage or wear monthly.
4. Keep the dust cover on the filling nozzle.
5. Monthly check the indicator lights on the FBS controller for proper operation while idling and when the engine is warm. Adjust if needed as described in the Start up and adjusting section above.
6. Monthly check the cylinder to be sure it is secure and does not have any damage. If your tank has any damage have it inspected by a certified tank inspector.

Troubleshooting

1. The engine does not run on CNG when in the CNG position. Check all fuses. Check the ground to the regulator and make sure all blue wires are connected together and connected to the solenoid. Make sure the solenoid nut is tight. To check the solenoid for proper operation, use a wire from the battery to the solenoid. You should hear a click sound each time you touch the wire to the solenoid. Do not connect the wire as CNG will flow while it is connected. Just tap the wire for less than one second at a time. Do this a few times and if it clicks each time it is working. If it does not click, test the solenoid. The solenoid should read about 17 ohms to ground with the blue wire disconnected. If the resistance is not correct you have a bad ground or the solenoid coil is bad. If it still does not work, connect a meter to the solenoid and ground and have someone try to convert to CNG while you read the voltage. If the voltage comes on for a second and then shuts off, the brown wire to the coil is not sending the proper signal to the Change-Over Controller. If there is no voltage, there is not a good ground, or connection to the solenoid or other wiring problem. Check all wiring.
2. The engine has little power and does not run well on CNG. Check the pressure gauge for proper CNG pressure and check all wiring. Adjust the idle screw as described in the Start up and Adjusting section. If this does not fix the problem, the filter on the regulator could be clogged. The regulator has a felt filter built into the inlet. To check or replace, turn off the cylinder valve. Loosen the top bolt on the regulator and remove the tee fitting which has the pressure gauge and high pressure fitting connected to it out of the way just enough to remove the filter. There is an o-ring on the top and bottom of the fitting so make sure you do not lose them. Insert needle nose pliers to remove the felt filter. It is located about 1/2" inside the regulator. Be careful to not lose the metal screen under the felt. Clean or replace the felt filter. Do not operate without the felt filter. Replace and tighten the tee fitting. Turn the cylinder valve back on and check for leaks and proper operation. If you suspect that the regulator is bad, which is very uncommon, we have rebuild kits available at a low cost.
3. The engine runs good on CNG but runs rough on gasoline. Check the voltage to the solenoid on the regulator while running on gasoline to make sure it does not have power. Check the ground and voltage to the gasoline solenoid. It should have power when running on gasoline. Make sure there are no leaks in the air intake hose. Make sure all injector wire harnesses are connected to the injector emulators. Make sure all wire connectors that were unplugged during installation are reconnected. Make sure anything else that was disconnected is reconnected.

Do not call your dealer or EWS with installation questions unless you are sure there is a problem with your conversion kit. It is your responsibility to install your kit. Study the instructions and drawings carefully. Call a friend for help or take your car to a repair shop for help if needed.